

SDR-DSP-IO-IQ-DIFF (-3)

- 1 Index
- 2 DSP interface connector, PCB dimensions, fixing points
- 3 DAC
- 4 ADC
- 5 Power

Board design is 4 layer FR-4 with following structure:

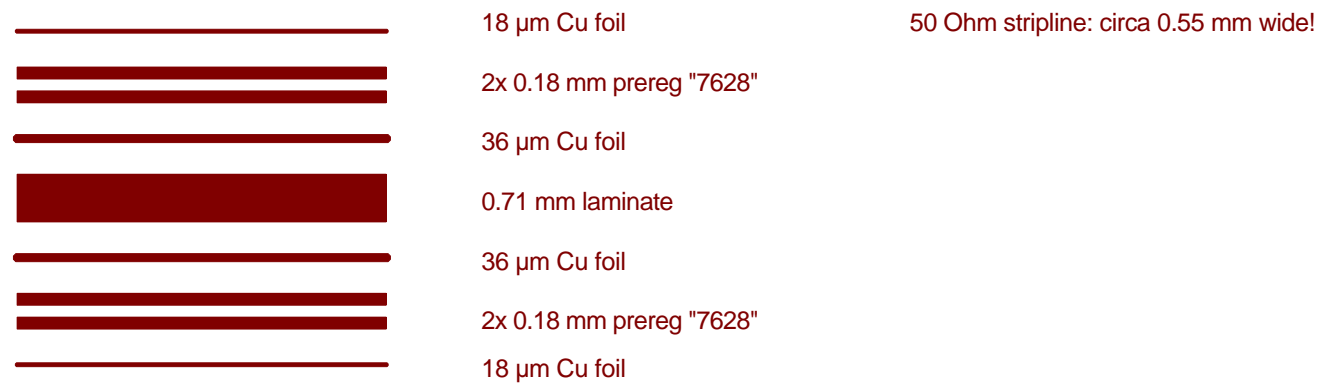

Copyright (c) Matti Aarnio OH2MQK

sdr-dsp-io-iq-diff-3
5/29/2006 00:14:58
Sheet: 1/5

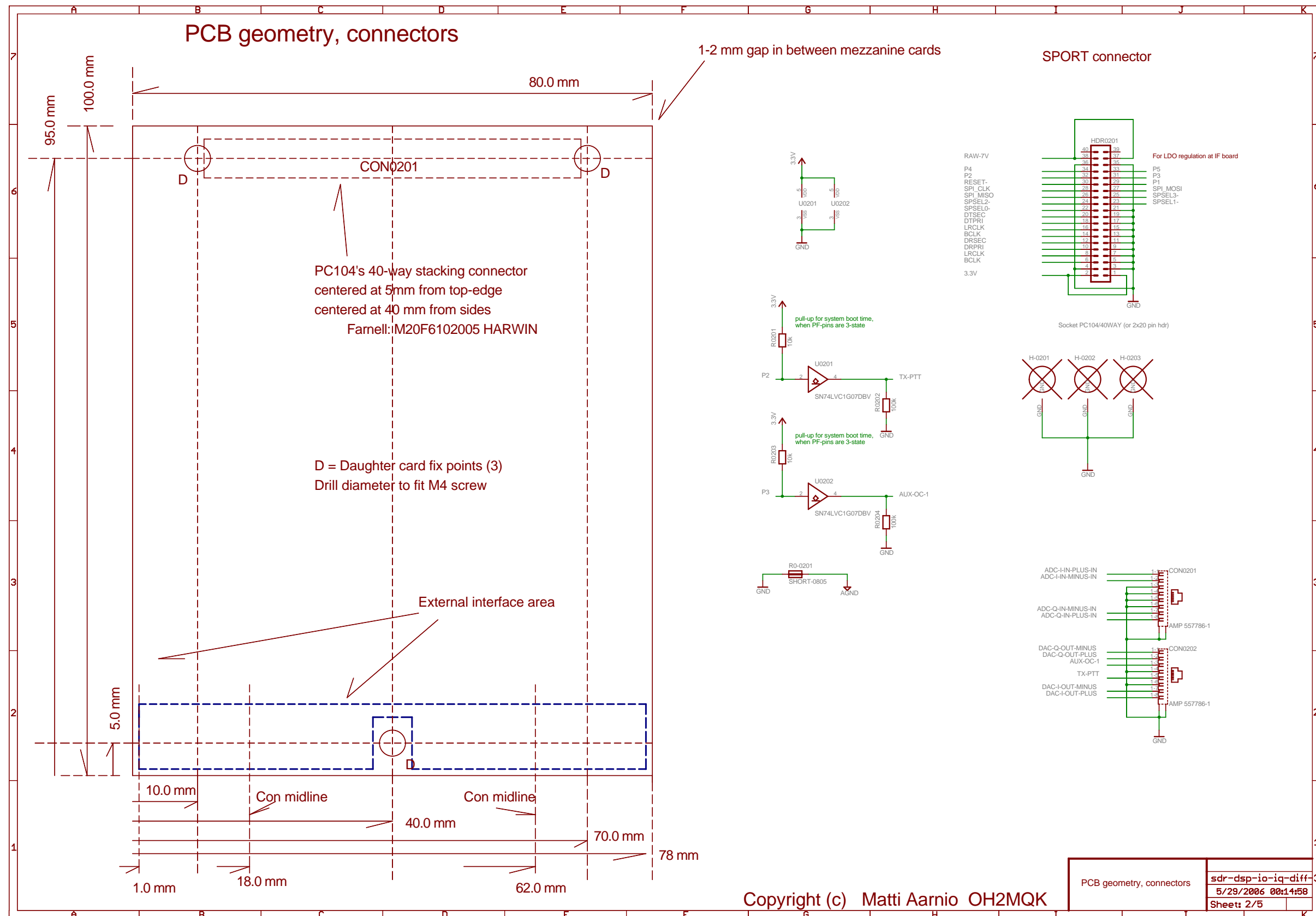

PCB geometry, connectors	sdr-dsp-io-iq-diff-3
	5/29/2006 00:14:58
	Sheet: 2/5

Copyright (c) Matti Aarnio OH2MQK

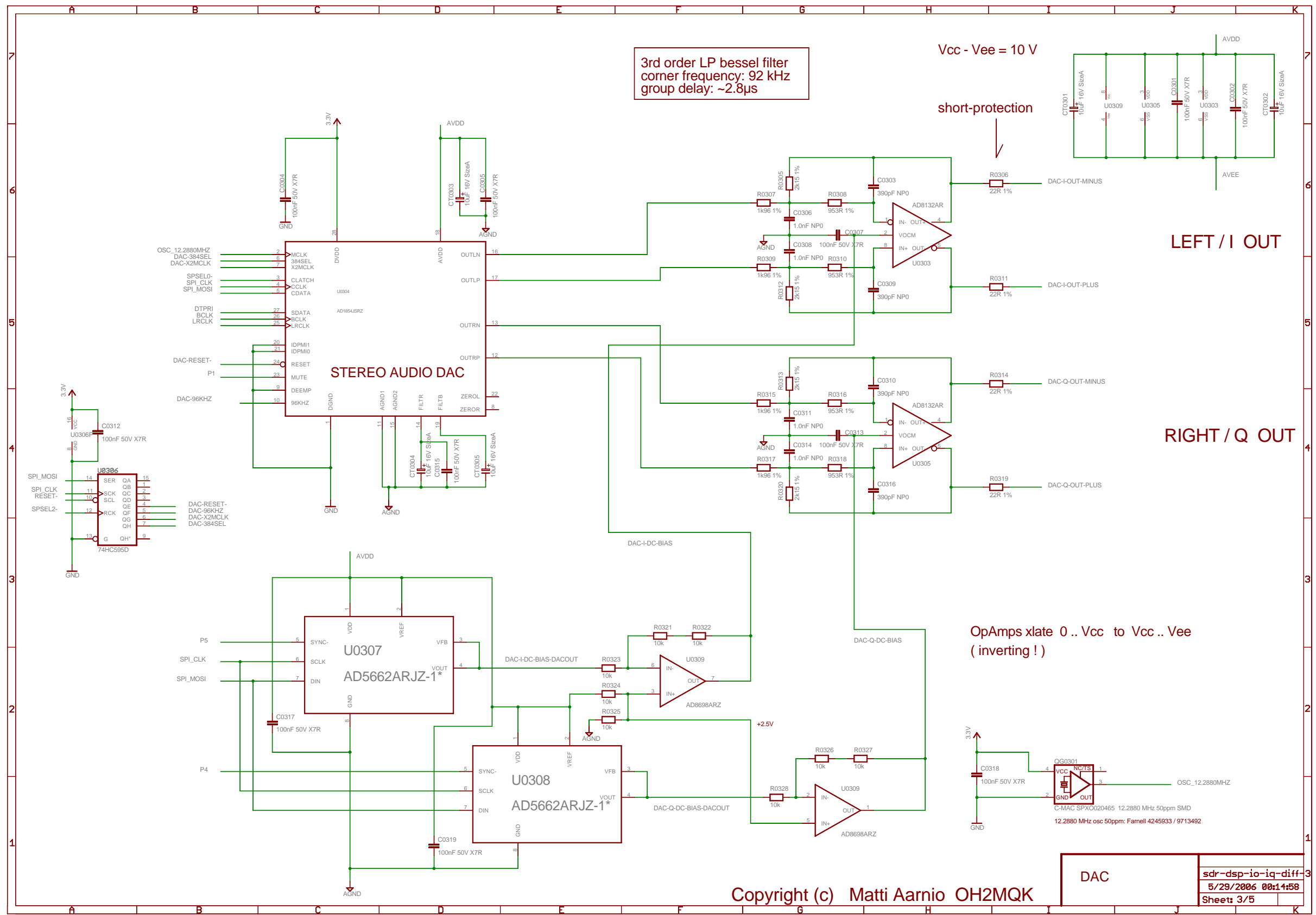

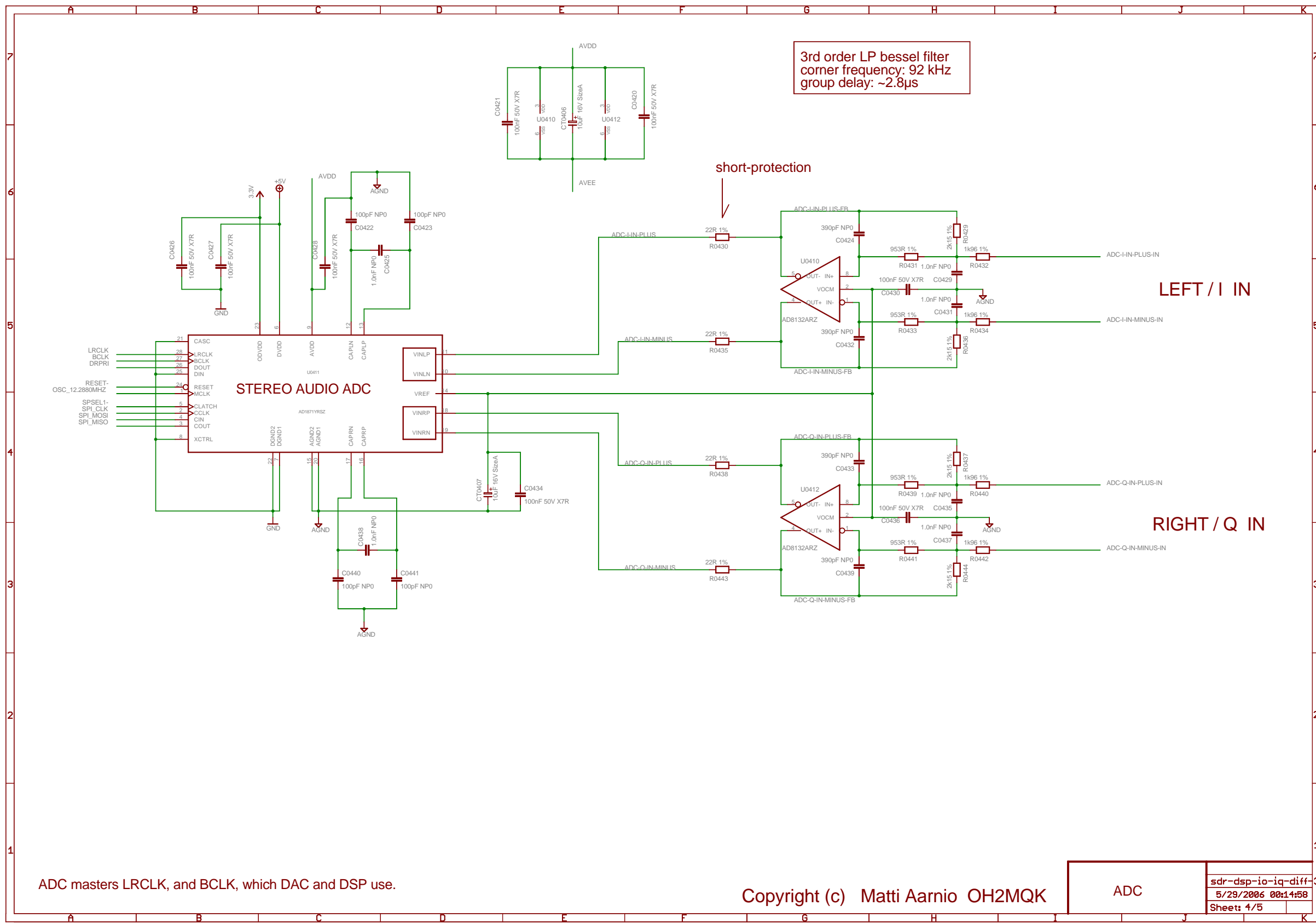

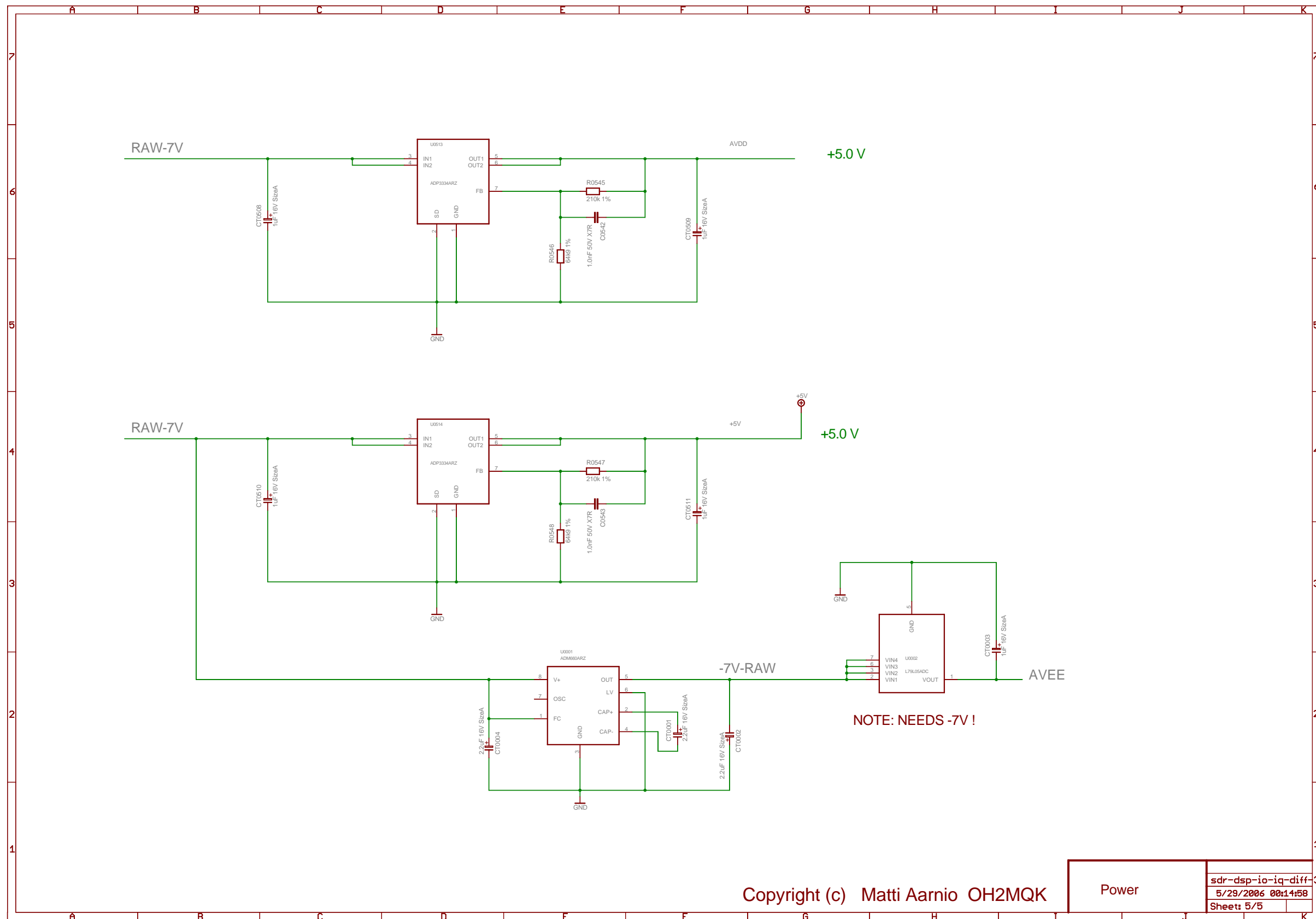

Copyright (c) Matti Aarnio OH2MQK

Power

sdr-dsp-io-iq-diff-3
5/29/2006 00:14:58
Sheet: 5/5